

Rotoplat TP3

MACCHINA A TAVOLA ROTANTE CON PIATTO SAGOMATO
PER CARICAMENTO CON TRANSPALLET
TURNTABLE WRAPPING MACHINE WITH SHAPED PLATE
FOR PALLET JACK LOADING



- Display touch a colori 7"
Color touch display 7"
- Interfaccia user-friendly
User-friendly interface
- 12 programmi impostabili
(con multilevel control)
12 Programs that can be set
(with multilevel control)



LAYOUT ROTOPLAT TP3 708 PVS [mm]

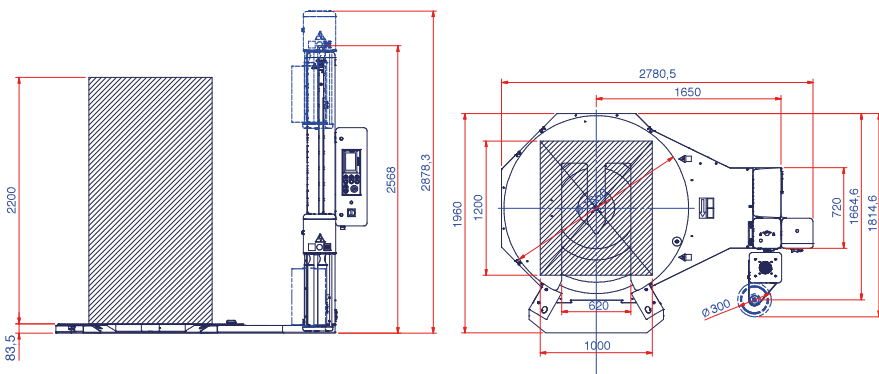

PERCHÈ ROTOPLAT TP3?

WHY ROTOPLAT TP3?

- **USABILITÀ** STUDIATA PER CARICAMENTO CON TRANSPALLET MANUALI
USABILITY DESIGNED FOR LOADING WITH HAND PALLET TRUCKS
- **FLESSIBILITÀ** GRAZIE AL NUOVO BASAMENTO PUÒ ESSERE INSTALLATA PER 3 DIVERSE LINEE DI CARICO
FLEXIBILITY THANKS TO THE NEW BASE, IT CAN BE INSTALLED IN 3 DIFFERENT LOADING LINES
- **SICUREZZA** DOTATA DI NUOVA RAMPA CON FOTOCELLULE DI SICUREZZA
SAFETY EQUIPPED WITH NEW RAMP WITH SAFETY PHOTOCELLS
- **FACILITÀ DI CARICO** NUOVA FORMA A V PER FACILITARE L'INGRESSO DEL TRANSPALLET
EASE OF LOADING NEW V SHAPE FOR EASY ENTRY OF THE PALLET TRUCK
- **ROBUSTEZZA** MAGGIOR SOLIDITÀ GRAZIE AL NUOVO SISTEMA DI ROTOLAMENTO DEL PIATTO
STURDINESS GREATER SOLIDITY THANKS TO THE NEW ROLLING SYSTEM OF THE PLATE



Grazie al basamento TP3, studiato per caricamento con transpallet, è possibile cambiare lato di carico in utenza scegliendo 3 configurazioni differenti a seconda delle esigenze del cliente.
Thanks to the TP3 turntable, designed for loading with hand pallet trucks, it is possible to change the load side in use by choosing 3 different configurations according to the customer's needs.



Caricamento laterale sinistro
Left side load



Caricamento frontale
Front load



Caricamento laterale destro
Right side load

CARATTERISTICHE TECNICHE TECHNICAL FEATURES

MACCHINA MACHINE	ROTOPLAT TP3 308 FR	ROTOPLAT TP3 508 PDS	ROTOPLAT TP3 708 PVS
diametro piatto / plate diameter (mm)		1650 std. 1800 opt.	
portata massima / max load weight (kg)		1500	
velocità rotazione piatto / plate rotation speed (rpm)		5÷12	
velocità salita-discesa carrello / carriage up-down speed (m/min)		1,5÷5,5	
tipo carrello / film carriage type	FR	PDS	PVS
tiro film / film tensioning		regolabile da pannello / adjustable from panel	
prestiro film / film pre-stretch	n.a.	fisso / fixed 250% std.	variabile / variable 150-400%
dimensioni massime pallet (LxW) / maximum pallet dimensions (LxW) (mm)		1000x1200 std. / 1200x1200 opt.	
altezza massima prodotto / maximum product height (mm)		2200 std. 2400/2800/3100 opt.	
alimentazione / power supply (V)		230 V 1Ph ±10% 50/60 Hz	
potenza installata / installed power (kW)	1,5	1,9	2,4
dimensioni massime bobina (HxØ) / max reel dimensions (HxØ) (mm)		500x300	
peso massimo bobina / max reel weight (kg)		20	
spessore film / film thickness (µm)		17÷35	
inforcabilità / forklifting		posteriore / rear	